

CALDARA

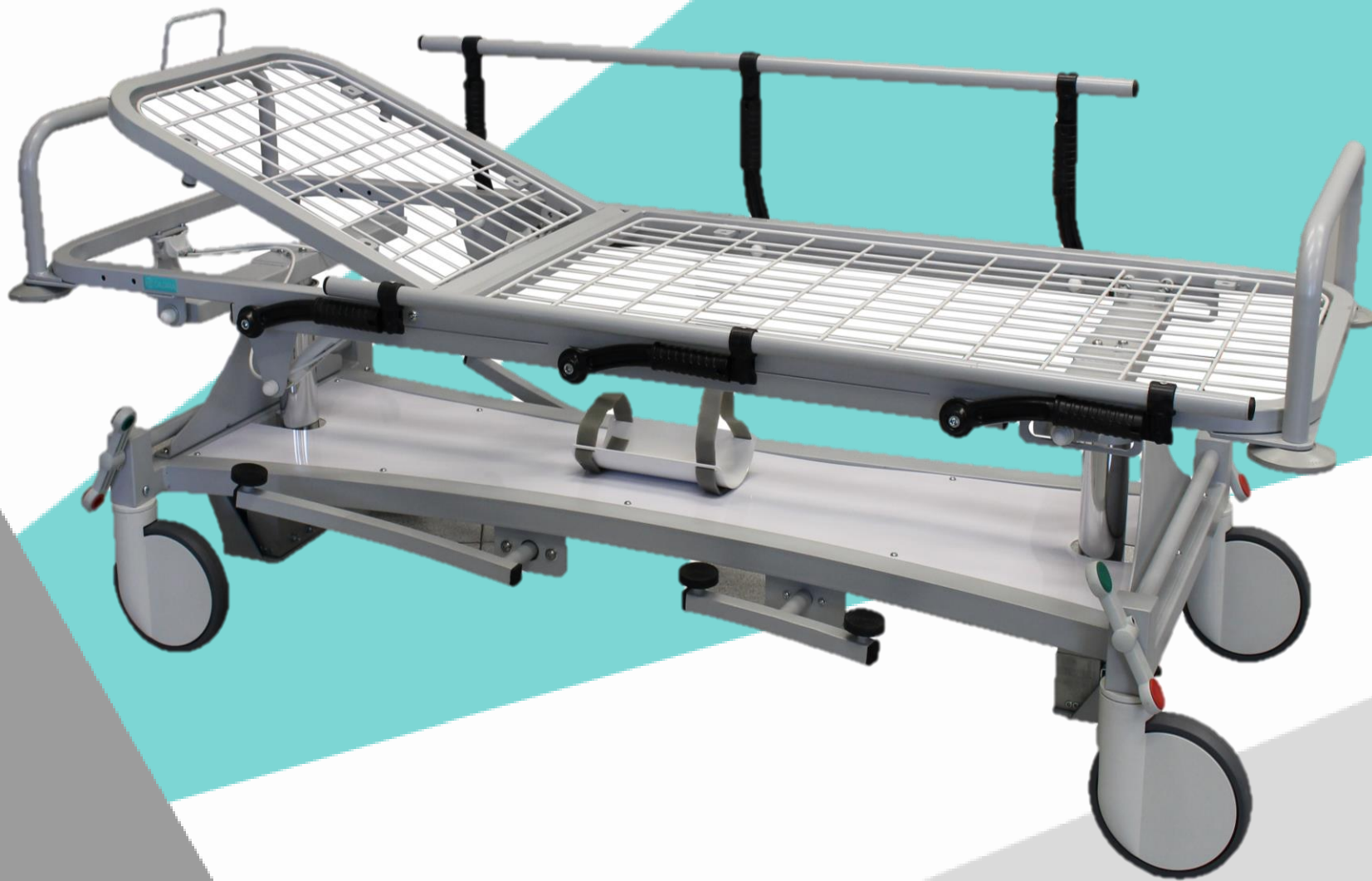

  
100% MADE IN ITALY

OW3XL.VHPO  
Height-adjustable stretcher



# OW3XL.VHPO

## BASIC CONFIGURATION

Height-adjustable structure by means of 2 hydraulic pumps with remarkable performance characteristics. The 3 pedals for height adjustment and inclination adjustment are present on both sides. The mesh surface of the upper frame can be removed to ensure better sanitation. The innovative design makes the stretcher absolutely solid and comfortable allowing operators to comfortably perform manoeuvres to the patient. The side rails are very practical and can be folded down quickly and easily. The structure is equipped with push handles, 4 bumpers at the corners and a universal cylinder holder. The cushion can be reclined by means of two easily operated gas springs thanks to the practical ergonomic lever, its inclination is 70°. The wheels are Ø 200 mm all with central and total simultaneous brake, one with a directional lock. The entire structure is painted with light grey epoxy powders. Thanks to its essential line it is easily washable and easy to sanitise. The pedals on both sides allow you to adjust the stretcher in height and to tilt the structure in the TR / RTR position.

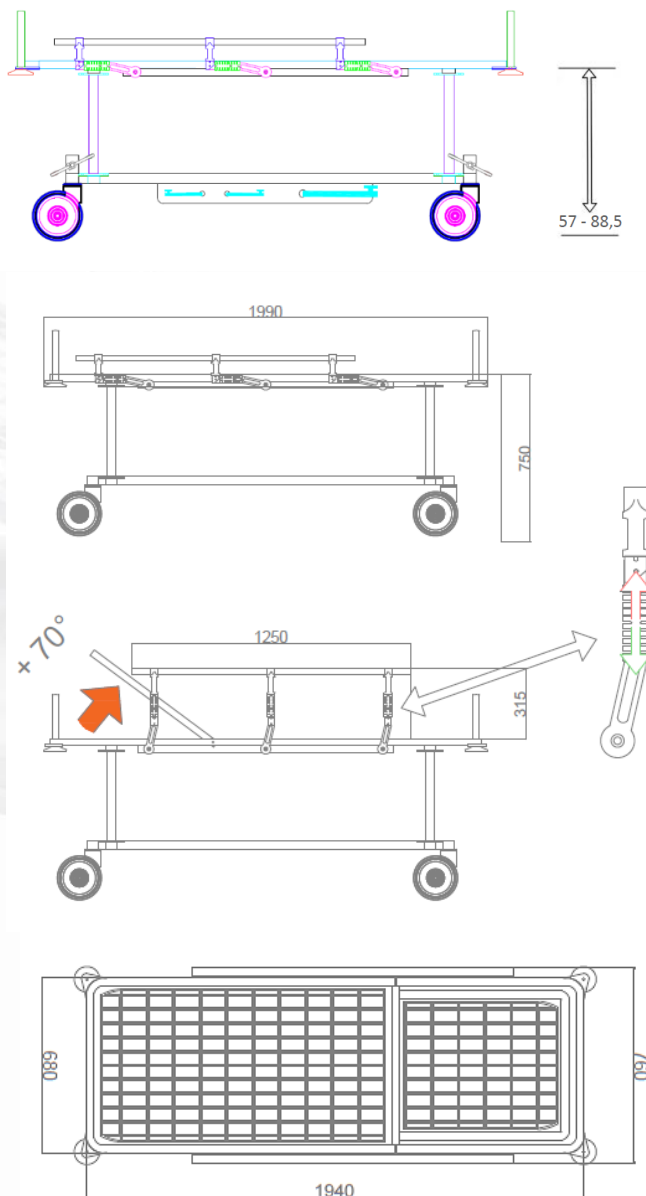

## TECHNICAL FEATURES

The construction materials are rectangular and round square tubular furniture from Uni 7947/81 and 8913, DIN2394, threaded bushings in AVP, plates in FE.

The structure follows a process of phospho-degreasing, rinsing and application of the powdered paint cured at 200 °, its minimum thickness is 70/80 microns. The finish is glossy. The maximum static load of the single vertical hydraulic pump is 300 daN. at 95 Bar.

The Ø 200 wheels have a static load capacity of 150 kg per single wheel, the brake is central simultaneously with 4 pedals; one of the 4 wheels also has a directional lock.



PORTATA  
CAPACITY



PESO  
WEIGHT

TRENDELENBURG/ ANTI TRENDELENBURG POSITION (-17°/+17°)



## MATTRESS COVER (OPT3.OW)



SFODERABILE  
REMOVABLE



ANTISTATICO  
ANTISTATIC



ANTIBATTERICO  
ANTIBACTERIAL



ANTIACARO  
ANTIACARUS



TRASPIRANTE  
BREATHABLE



IGNIFUGO  
FIREPROOF



STERILIZZABILE  
STERILIZABLE



SPESSORE  
THICKNESS



IMPERMEABILE  
WATERPROOF

## AVAILABLE COLOURS



## OPTIONAL

- OPT1.OW - IV pole
- OPT3.OW - Removable, antistatic, antibacterial, anti-mite, breathable, fireproof, waterproof and sterilisable mattress H. 8 cm
- OPT5.OW - 4 wheels Ø 200 mm with simultaneous central brake
- OPT6.OW - 4 wheels Ø 200 mm with central brake, simultaneous conductive
- OPT7.OW - Upper surface in radiolucent carbon (when ordering please request a level of transparency 0.6 / 0.7 mm aluminum sp)
- OPT8.OW - Universal storage
- OPT9.OW - Fifth wheel Ø 125 mm

## CONFORMITY

Class 1 medical device compliant with the requirements of the EEC directive 93/42.

### NATIONAL CLASSIFICATION OF MEDICAL DEVICES (CND)

Manufacturer: CALDARA SRL

Code attributed by CALDARA SRL: OW3XL.VHPO

CND classification: Y123099

Progressive number assigned by the system (RDM): 1713249/R



web link

**CALDARA SRL**

Via Trieste 31/B  
22036 Erba (CO)

Italy

PH: +39 031640896

[info@caldarasrl.it](mailto:info@caldarasrl.it)

[www.caldarasrl.it](http://www.caldarasrl.it)