

CALDARA



100% MADE IN ITALY

MO00047/R
Blood collection/relax synchro armchair
with wheels



MO00047/R

BASIC CONFIGURATION

The armchair is made of metal with an oval, square and round section. An oval tubular 50x25x1.5 was used for the legs; for the central frame a 30x30x1.5 square and for the cushions a round pipe diam.25x1.5. The structure is entirely painted with white epoxy powder.

The top in fireproof high-density class 1 IM rubber is covered in class 1 IM flame-retardant coated (skai) fabric. The synchronized adjustment of the two cushions is adjustable by means of a gas spring activated by a comfortable handle placed behind the backrest. The inclination of the backrest is equal to about -5° in the Trendelenburg.

The armrests are equipped with a joint that guarantees a perfect inclination during their use; they can be adjusted in height and extracted rotated 180° . The wheels are swivelling 2 with total brakes.

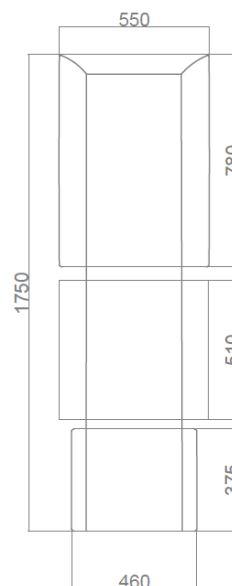
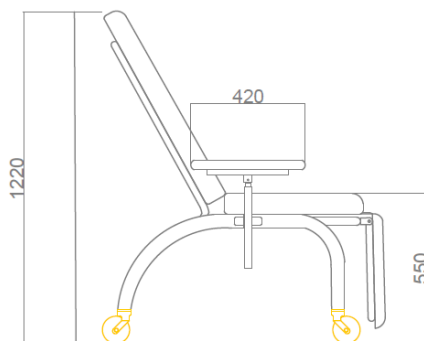

TECHNICAL FEATURES

The construction materials are square oval tubular and round furniture from Uni 7947/81 and 8913, DIN 2394, threaded bushings in AVP, Fe plates. The padded top has a wooden material base, the class 1 Im fireproof expanded polyurethane padding is covered with a class 1 Im fireproof coated fabric (skai, imitation leather). The structure follows a process of phospho-degreasing, rinsing and application of the polymerised powder paint at 200° . The colour is white Ral. 9003, its minimum thickness is 70/80 microns. The finish is glossy.



PORTATA
CAPACITY



PESO
WEIGHT

PADDING

The padding is in high density rubber, its cover is in fireproof class 1 IM coated fabric (skai, imitation leather), washable with common detergents on the market.



IMPERMEABILE
WATERPROOF



IGNIFUGO
FIREPROOF

AVAILABLE COLOURS



OPTIONAL

- MO00052 - Paper roll-holder
- A1.MO47 - IV Pole
- A3.MO47 - Push handle
- A4.MO47 - 4 castors, 2 with directional brake



CONFORMITY

Class 1 medical device compliant with the requirements of the EEC directive 93/42.

NATIONAL CLASSIFICATION OF MEDICAL DEVICES (CND)

Manufacturer: CALDARA SRL

Code attributed by CALDARA SRL: MO00047/R

CND classification: V0802

Progressive number assigned by the system (RDM): 1994938/R



web link

CALDARA SRL

Via Trieste 31/B
22036 Erba (CO)

Italy

PH: +39 031640896

info@caldarasrl.it

www.caldarasrl.it