

CALDARA



100% MADE IN ITALY

MO00047/E

Electric-synchro blood collection/relax armchair



MO00047/E

BASIC CONFIGURATION

The armchair is made of metal with oval section, square and round. A 50x25x1.5 oval tubular was used for the legs; for the central frame a 30x30x1.5 square and for the cushions a round tube diam.25x1.5. The structure is completely painted with white epoxy powder.

The top in high-density rubber is covered in fireproof (class 1 IM) coated fabric (skai). The synchronized adjustment of the two cushions is adjustable by an electric actuator with a push-button control. The inclination of the back is equal to -5° in Trendelenburg position c.a.

The armrests are known as articulated joints which guarantee a perfect inclination during their use; they can be adjusted in height and extracted by 180° rotation. There are four adjustable feet that embraces optimal stability.

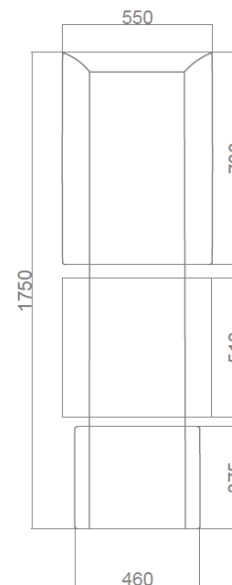
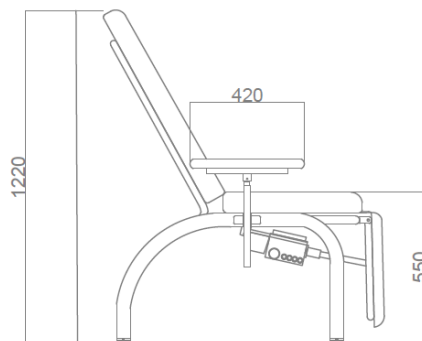

TECHNICAL FEATURES

The construction materials are oval, square and round furniture tubes Uni 7947/81 and 8913, DIN 2394, threaded bushes in AVP, flat in Fe.

The padded top has a base in wooden material, the padding in fire retardant polyurethane foam class 1 Im is covered in coated fabric (skai, imitation leather) fire retardant class 1 Im.

The structure follows a process of phospho-degreasing, rinsing and application of the powder paint polymerized at 200° . The colour is Ral white. 9003, its minimum thickness is 70/80 microns. The finish is glossy.



PORTATA
CAPACITY



PESO
WEIGHT

PADDING

The padding is in high density rubber, its cover is in fireproof class 1 IM coated fabric (skai, imitation leather), washable with common detergents on the market.



IMPERMEABILE
WATERPROOF



IGNIFUGO
FIREPROOF

AVAILABLE COLOURS



OPTIONAL

- MO00052 - Paper roll-holder
- A1.MO47 - IV Pole
- A3.MO47 - Push handle



CONFORMITY

Class 1 medical device compliant with the requirements of the EEC directive 93/42.

NATIONAL CLASSIFICATION OF MEDICAL DEVICES (CND)

Manufacturer: CALDARA SRL

Code attributed by CALDARA SRL: MO00047/E

CND classification: V0802

Progressive number assigned by the system (RDM): 1994702/R



web link

CALDARA SRL

Via Trieste 31/B
22036 Erba (CO)
Italy

PH: +39 031640896

info@caldarasrl.it

www.caldarasrl.it